

Pearson BTEC Level 5 Higher Nationals in Engineering (RQF)

Unit 45: Industrial Systems

Unit Workbook 4

in a series of 4 for this unit

Learning Outcome 4

Performance Analytics

Contents

INTRODUCTION	3
GUIDANCE	3
4.1 Performance Analysis Methods	4
4.1.1 Full Load Measurement	4
4.1.2 Single Transaction Measurement	4
4.1.3 Full Load or Single Transaction: Which is Best?	4
4.1.4 Hybrid Example	5
4.2 Current Trends in Engineering	7
4.2.1 Reducing Human Monitoring	7
4.2.2 Sustainability	7
4.2.3 Climate Change	9
4.3 What This Means for Industrial Systems	10
4.3.1 Reducing Human Monitoring	10
4.3.2 Climate Change	10
4.3.3 Sustainability	11
4.4 Digital Development	12
4.4.1 Moore’s Law	12
4.4.2 Systems Communication	13
4.5 The Internet of Things	14
4.5.1 Current Smart Systems	14
4.5.2 Data Concerns	14

INTRODUCTION

Apply appropriate analytical techniques to predict the performance of a given system

- Consideration of current trends in technology, including the future of industrial systems
- The impact of digital developments, the increase of wireless and remote control and the Internet of Things.

GUIDANCE

This document is prepared to break the unit material down into bite size chunks. You will see the learning outcomes above treated in their own sections. Therein you will encounter the following structures;

Purpose

Explains *why* you need to study the current section of material. Quite often learners are put off by material which does not initially seem to be relevant to a topic or profession. Once you understand the importance of new learning or theory you will embrace the concepts more readily.

Theory

Conveys new material to you in a straightforward fashion. To support the treatments in this section you are strongly advised to follow the given hyperlinks, which may be useful documents or applications on the web.

Example

The examples/worked examples are presented in a knowledge-building order. Make sure you follow them all through. If you are feeling confident then you might like to treat an example as a question, in which case cover it up and have a go yourself. Many of the examples given resemble assignment questions which will come your way, so follow them through diligently.

Question

Questions should not be avoided if you are determined to learn. Please do take the time to tackle each of the given questions, in the order in which they are presented. The order is important, as further knowledge and confidence is built upon previous knowledge and confidence. As an Online Learner it is important that the answers to questions are immediately available to you. Contact your Unit Tutor if you need help.

Challenge

You can really cement your new knowledge by undertaking the challenges. A challenge could be to download software and perform an exercise. An alternative challenge might involve a practical activity or other form of research.

Video

Videos on the web can be very useful supplements to your distance learning efforts. Wherever an online video(s) will help you then it will be hyperlinked at the appropriate point.

4.1 Performance Analysis Methods

Performance analysis methods are used to analyse the performance of a system. These methodologies are used to provide a starting point to eventually hone in on an issue's root cause. There is a range of methodologies that can be used, as no single one will be used to solve all problems for all cases, and some problems may need to apply more than one methodology to analyse the performance.

Performance analysis adds structure to what would be a guessing game of “what’s wrong” and taking a blind approach to changing random factors and hoping that fixes the problem. The blind approach can be considered to be an “anti-method”; it is based entirely on luck, and those who are unlucky could cause huge delays in the process. There are two methods for performance analysis:

- Full load measurement
- Single transaction measurement

4.1.1 Full Load Measurement

Full load measurement is to run the system under a full production load, this is useful to gather all information that is measurable only under high-system loading. Full load measurement should always be done as there will be a rapid degradation in performance after a threshold is exceeded and the system reaches its ultimate load (the point at which the system will completely fail – much like ultimate tensile stresses in materials).

4.1.2 Single Transaction Measurement

Single transaction measurement is an isolation technique used to gather information about the individual components, and understanding how they would work. The system will need all the individual components to run at their optimum performance if the system is to do the same.

4.1.3 Full Load or Single Transaction: Which is Best?

Performance analysis should normally be planned around a full-load measurement test, but the performance constraints may vary at different times of the day, if you consider a number of factors (testing the acceleration of a car may depend on the windspeed, and can also affect fuel efficiency).

If the full load performance analysis does not show any serious problems, or if the system is not achieving the expected performance levels. Then the system needs to be isolated to examine each of the subsystems to ensure that they are running to their desired performance.

To ensure that these tests will succeed, the diagnostics team will need the appropriate data sets, but they will also need to ask the following:

- Is the performance fluctuating, or is it consistently below the expected level?
- Are performance issues related to a specific time or environmental factor?
- Has the system had a change recently and have these changes been fully documented?

4.1.4 Hybrid Example

Consider the example of a hybrid powertrain. The hybrid powertrain will be considered as a “series” system, meaning the output will be solely electrical, the power-flow of which can be seen in Fig.4.1 below, of course there will be much more monitored in the system, but this example will concern itself with the main components: the engine, generator, battery and output (in this case the motor).

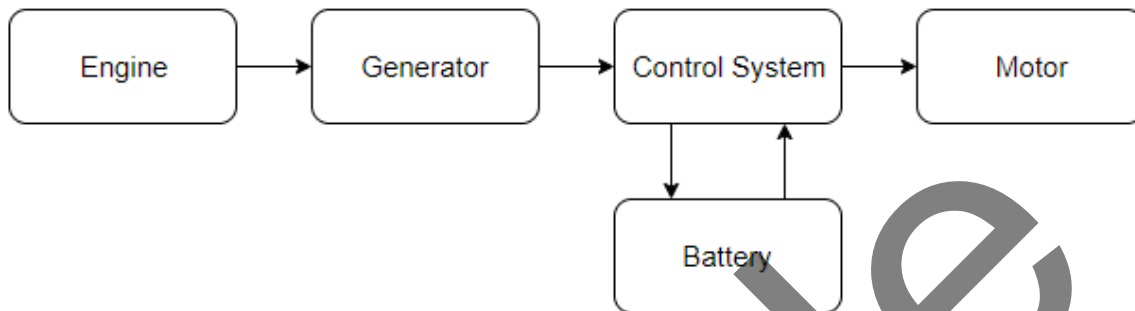

Fig.4.1: A series hybrid's main components

The performance of the system will typically be analysed by switching the system between its “power-modes”, which will revolve around the following:

- Battery Discharging, Generator off
- Battery discharging, Generator on
- Battery charging, Generator on

These are not the only power modes, as there are several configurations a hybrid system designs that can be produced, each with their own advantages and disadvantages. The system is broken down into several components for isolated testing:

- The engine:
 - Engine temperature
 - Fuel intake
 - Air intake
 - Engine revolutions
 - Anti-knock sensors
 - Fuel tank
- The battery bank:
 - Temperature
 - Current drawn from each battery
 - Voltage of each battery
- The generator:
 - Generator Temperature
 - Electromagnetic torque produced
 - Rotational speed

- Current drawn
- Voltage produced
- The motor:
 - Motor temperature
 - Speed
 - Torque

Analysing isolated performance will help determine the part (or parts) that are not performing at the optimal level. However, it's important to consider certain factors that may alter performance, such as:

- The engine:
 - The quality of fuel used.
 - The quality of air (some lab tests will use oxygen rich air to compensate for laboratory conditions).
 - Has the engine had a cold or hot start up?
 - The quality of the oil, or the bearings
- The battery bank:
 - Battery performance is very dependent on their temperature, as they use chemical reactions.
 - Different battery chemistries will exhibit
- Generator and motor
 - Increased heat output in the system can weaken the magnets
 - The waste heat produced by the resistance in the wiring will increase losses further
 - Is there slip in the contacts between the engine and generator?
 - Is there slip in the contacts between the motor and the wheels?
 - The quality of the bearings.

By considering these factors, it will be possible to discuss whether or not this change in performance is expected due to a certain factor, or if the component will need to be replaced.