

Pearson BTEC Level 5 Higher Nationals in Engineering (RQF)

Unit 52: Further Electrical, Electronic and Digital Principles

Unit Workbook 1

in a series of 4 for this unit

Learning Outcome 1

Steady-State and AC Circuit Analysis

Contents

1.1	Formal Steady-State Circuit Analysis	3
	Determinants	3
	Mesh Analysis.....	5
	Nodal Analysis	8
	Comparison between Mesh and Nodal Analysis	10
	Ideal Sources	10
	Superposition Theorem	11
	Complex Notation, Polar/Cartesian Forms and Phasor Diagrams.....	13
	Manipulating Complex Numbers	16
1.2	AC Circuit Analysis.....	18
	Series Resonant Circuits.....	18
	Parallel Resonant Circuits.....	22
	Power	27

Sample

1.1 Formal Steady-State Circuit Analysis

Determinants

When we are examining circuits with two loops, we arrive at two simultaneous equations with two unknowns. A circuit with three loops will produce three simultaneous equations with three unknowns.

For example, two loops ...

$$a_1x + b_1y + c_1 = 0$$

$$a_2x + b_2y + c_2 = 0$$

The objective is to find those values for x and y . Using **Determinants** is usually an effective method to find these. Let's use a **D** to represent a determinant, and then explain how they are used ...

$$\frac{x}{D_x} = \frac{-y}{D_y} = \frac{1}{D}$$

Where;

$$D_x = \begin{vmatrix} b_1 & c_1 \\ b_2 & c_2 \end{vmatrix} = (b_1 \times c_2) - (b_2 \times c_1)$$

$$D_y = \begin{vmatrix} a_1 & c_1 \\ a_2 & c_2 \end{vmatrix} = (a_1 \times c_2) - (a_2 \times c_1)$$

$$D = \begin{vmatrix} a_1 & b_1 \\ a_2 & b_2 \end{vmatrix} = (a_1 \times b_2) - (a_2 \times b_1)$$

The determinant of a square matrix is very useful in finding unknown quantities (like currents, voltages etc.) in systems of equations. Let's see if we can find the determinant for an actual 2 X 2 matrix...

$$\begin{vmatrix} 6 & -2 \\ 3 & 4 \end{vmatrix} = (6 \times 4) - (-2 \times 3) = 24 + 6 = 30$$

Notice that the determinant has been placed within special symbols $\begin{vmatrix} & \\ & \end{vmatrix}$.

What we do is to multiply the numbers on the leading diagonal (6 X 4) and then subtract the numbers on the other diagonal (-2 X 3). That obviously gives 30. This is non-zero, so that tells us that the solution should be unique (i.e. we can easily find the unknown quantities).

A few more examples...

$$\begin{vmatrix} 5 & 3 \\ 2 & 4 \end{vmatrix} = 14$$

$$\begin{vmatrix} -6 & 8 \\ 2 & -4 \end{vmatrix} = 8$$

$$\begin{vmatrix} -6 & 2 \\ 9 & 3 \end{vmatrix} = -36$$

$$\begin{vmatrix} 3 & 18 \\ 2 & 12 \end{vmatrix} = 0$$

Now let's see what happens with the determinant of a 3 x 3 matrix. Each cell (element) in a 3 x 3 matrix has a **minor**, which is found by covering up the corresponding row and column which contains that minor, and then evaluating its determinant. Let's look at an example ...

$$\begin{bmatrix} 1 & 2 & 3 \\ 4 & 5 & 6 \\ 7 & 8 & 9 \end{bmatrix}$$

The minor of element 4 is obtained by covering up its row and column, like this ...

$$\begin{bmatrix} 1 & 2 & 3 \\ 4 & 5 & 6 \\ 7 & 8 & 9 \end{bmatrix}$$

Now remove those red elements and we have ...

$$\begin{bmatrix} 2 & 3 \\ 8 & 9 \end{bmatrix}$$

Change this matrix into a determinant and that will be the minor of element 4 ...

$$\begin{vmatrix} 2 & 3 \\ 8 & 9 \end{vmatrix} = (2 \times 9) - (3 \times 8) = 18 - 24 = -6$$

So, the minor of element 4 is -6.

There is still a bit more to consider. We have a sign associated with each minor, and this is really important. Let's see how this sign 'pattern' works ...

$$\begin{pmatrix} + & - & + \\ - & + & - \\ + & - & + \end{pmatrix}$$

We see that element 4 lives on row 2 column 1, which requires a '-' sign. We therefore need to write ...

$$-(-6) = 6$$

Once we introduce the sign to a minor we call it the **cofactor**.

Now we are in a position to evaluate the determinant of a 3 x 3 matrix. Let's look at an example ...

$$\begin{vmatrix} 4 & 2 & -1 \\ 6 & -2 & 0 \\ 1 & -4 & 8 \end{vmatrix}$$

We can actually pick any row or column we like to determine the sum of products of any row or column and its cofactors. Why make life hard for ourselves when we see that there is a 0 in column 3, row 2; making those multiplications zero and shortening our work. Here's how it goes ...

$$\begin{aligned} \begin{vmatrix} 4 & 2 & -1 \\ 6 & -2 & 0 \\ 1 & -4 & 8 \end{vmatrix} &= -6 \begin{vmatrix} 2 & -1 \\ -4 & 8 \end{vmatrix} + (-2) \begin{vmatrix} 4 & -1 \\ 1 & 8 \end{vmatrix} + 0 \begin{vmatrix} 4 & 2 \\ 1 & -4 \end{vmatrix} \\ &= -6 \begin{vmatrix} 2 & -1 \\ -4 & 8 \end{vmatrix} + (-2) \begin{vmatrix} 4 & -1 \\ 1 & 8 \end{vmatrix} \\ &= -6((2 \times 8) - (-1 \times -4)) - 2((4 \times 8) - (-1 \times 1)) \\ &= -6(16 - 4) - 2(32 - -1) \\ &= -6(12) - 2(33) \\ &= -72 - 66 = \mathbf{-138} \end{aligned}$$

Please test this out with [this online calculator](#). You will find that it is correct.

Now we are in a position to put determinants to very good use in our circuit analyses ...

Mesh Analysis

When we talk of a 'steady state' DC analysis we are effectively saying that all capacitors are fully charged and all inductors have fully energised their magnetic fields. In this scenario, capacitors can be replaced with open circuits and inductors replaced with short circuits.

What this means is that should we have a steady-state series RC circuit connected across a battery, because the capacitor is considered to be open circuit in the steady state, no current flows – all of the battery voltage is across the capacitor.

If we considered a steady-state series RL circuit connected across a battery, because the inductor is considered to be a short circuit in the steady-state, the resistor will effectively be connected directly across the battery – current will be given by the battery voltage divided by the resistor value.

A circuit mesh is simply a closed loop. Let's look at a circuit which contains two meshes ...

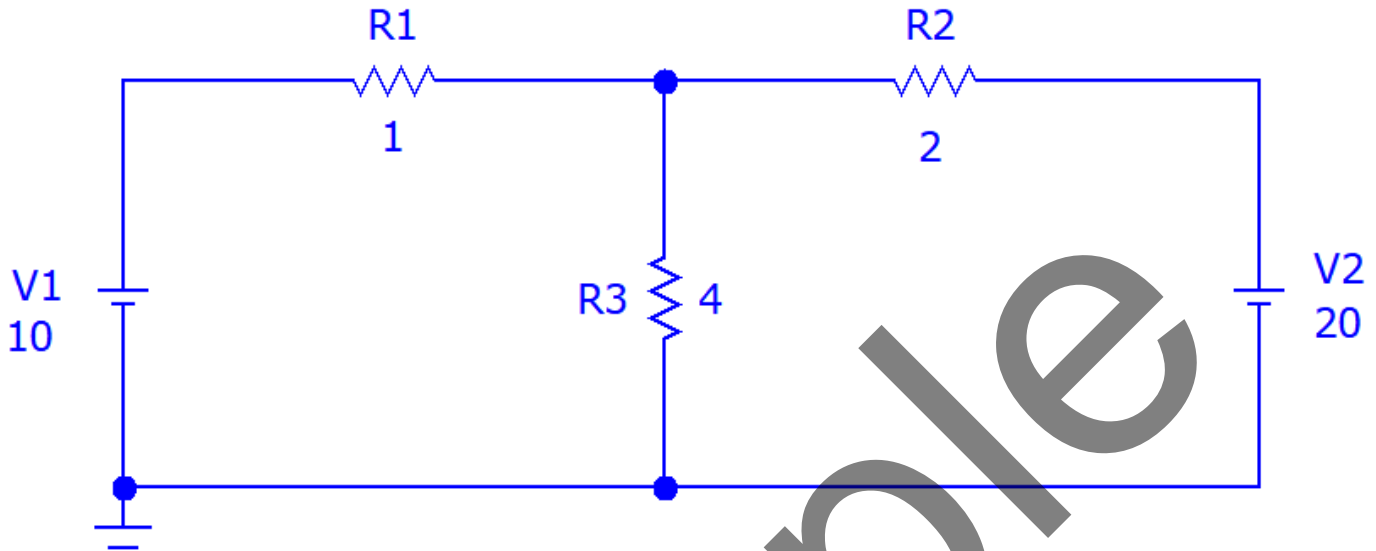

Figure 1: A two-mesh DC circuit

Here V1, R1 and R3 form mesh 1. V2, R2 and R3 form mesh 2. Let's indicate the circulating currents in each mesh ...

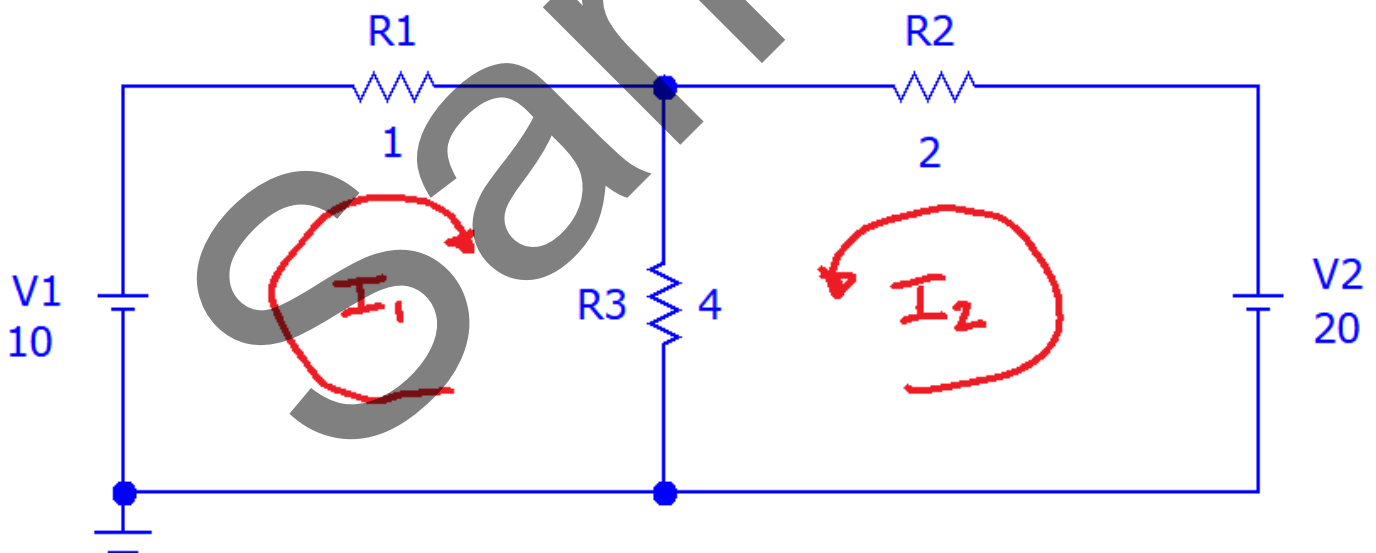

Figure 2: A two-mesh DC circuit with circulating currents

In mesh analysis we remember Kirchoff's Voltage Law (KVL) – the sum of voltages in any closed loop (mesh) is zero. With this in mind, let's start the analysis of these meshes.

Mesh 1

$$I_1 R_1 + (I_1 + I_2) R_3 = 10$$

$$\therefore (R_1 + R_3) I_1 + R_3 I_2 - 10 = 0$$

Put in the resistor values...

$$5I_1 + 4I_2 - 10 = 0 \quad [1]$$

Mesh 2

$$I_2 R_2 + (I_2 + I_1) R_3 = 20$$

$$\therefore R_3 I_1 + (R_2 + R_3) I_2 - 20 = 0$$

Put in the resistor values...

$$4I_1 + 6I_2 - 20 = 0 \quad [2]$$

Let's bring together equations [1] and [2] because they describe the circuit behaviour, and will form the basis of our analysis using determinants.

$$5I_1 + 4I_2 - 10 = 0 \quad [1]$$

$$4I_1 + 6I_2 - 20 = 0 \quad [2]$$

The determinants are ...

$$D_{I1} = \begin{vmatrix} 4 & -10 \\ 6 & -20 \end{vmatrix} = (4 \times -20) - (-10 \times 6) = -80 - -60 = -80 + 60 = -20$$

$$D_{I2} = \begin{vmatrix} 5 & -10 \\ 4 & -20 \end{vmatrix} = (5 \times -20) - (-10 \times 4) = -100 - -40 = -100 + 40 = -60$$

$$D = \begin{vmatrix} 5 & 4 \\ 4 & 6 \end{vmatrix} = (5 \times 6) - (4 \times 4) = 30 - 16 = 14$$

Earlier we discovered ...

$$\frac{x}{D_x} = \frac{-y}{D_y} = \frac{1}{D}$$

But, we are not using x and y here, so we replace them with I_1 and I_2 ...

$$\frac{I_1}{D_{I1}} = \frac{-I_2}{D_{I2}} = \frac{1}{D}$$

$$\therefore I_1 = \frac{D_{I1}}{D} = \frac{-20}{14} = -1.429 \text{ A}$$

$$\therefore I_2 = \frac{-D_{I2}}{D} = \frac{-(-60)}{14} = \frac{60}{14} = 4.286 \text{ A}$$

Using the [MicroCap simulator](#), we perform a Dynamic DC analysis on this circuit to prove that our method and calculations are correct ...

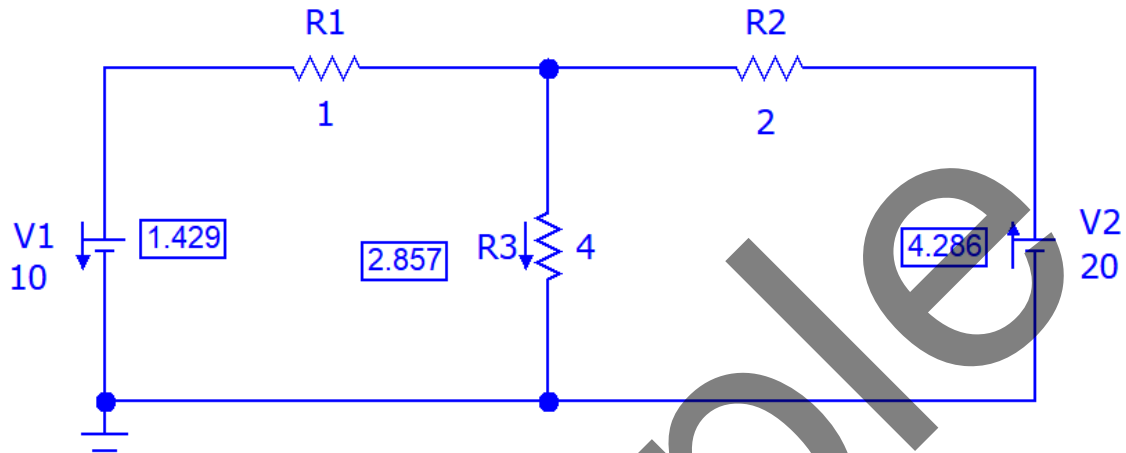

Figure 3: A two-mesh DC circuit with current simulations

Although we initially assumed that our circulating I_1 current was flowing clockwise, the analysis actually proves that it is flowing anticlockwise (the current arrow is pointing downwards for 1.429 A).

Nodal Analysis

Nodal analysis relies on Kirchoff's Current Law (KCL) – the algebraic sum of currents at any junction is zero. Let us again look at the circuit analysed in the previous section ...

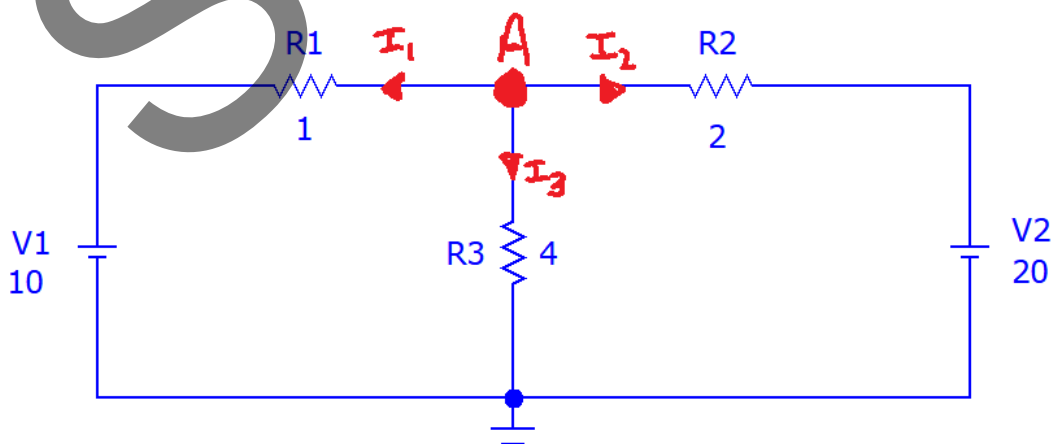

Figure 4: A 4-node DC circuit