

Pearson BTEC Level 5 Higher Nationals in Engineering (RQF)

Unit 63: Industrial Services

Unit Workbook 1

in a series of 4 for this unit

Learning Outcome 1

Electrical Power and Lighting

CONTENTS

INTRODUCTION	4
GUIDANCE	4
Electrical Power.....	5
Polyphase Induction Motors.....	5
Essentials.....	5
Operation	5
Starting.....	8
Speed Control.....	9
Three-Phase Transformers.....	10
Essentials.....	10
Construction.....	10
Vector Group.....	12
Clock number	13
Parallel Operation	15
Electrical Distribution.....	16
Three-phase distribution methods and connections.....	16
Single-phase distribution methods and connections	17
Earthing system connections	18
TT System	19
TN-C System	19
TN-S System	20
TN-C-S System.....	20
IT System.....	21
Transformer Efficiency.....	22
Electrical Circuit Symbols	23
Electrical Layout Diagrams.....	24
Fault finding techniques and test equipment.....	25
Input/Output.....	25
Half Split	25
Meters.....	25
Insulation Testers.....	27
Typical Faults.....	27
Lighting Circuits.....	29

Residential Lighting.....	29
Commercial Lighting.....	30
Types of lights available	31
HID Lighting.....	31
Metal-Halide.....	31
Sodium	32
Fluorescent Lighting.....	32
Halogen Lighting.....	33
LED Lighting.....	33
Lighting Applications and Parameters	35
Safety and heat in hazardous areas	36
Lighting Design	36
Residential lighting design	36
Outdoor lighting design	37
Emergency lighting.....	37

SAMPLE

INTRODUCTION

Apply the operating principles of electrical power and lighting Systems

Electrical power:

Construction, starting and speed control of polyphase induction motors.

Three-phase transformers: construction, clock number and group, parallel operation.

Electrical distribution: power system topologies, efficiency, power factor causes and correction, effect on cost of supplies, circuit protection.

Lighting systems:

Lighting fundamentals: SI units, energy efficient circuit design and layout.

GUIDANCE

This document is prepared to break the unit material down into bite size chunks. You will see the learning outcomes above treated in their own sections. Therein you will encounter the following structures;

Purpose

Explains *why* you need to study the current section of material. Quite often learners are put off by material which does not initially seem to be relevant to a topic or profession. Once you understand the importance of new learning or theory you will embrace the concepts more readily.

Theory

Conveys new material to you in a straightforward fashion. To support the treatments in this section you are strongly advised to follow the given hyperlinks, which may be useful documents or applications on the web.

Example

The examples/worked examples are presented in a knowledge-building order. Make sure you follow them all through. If you are feeling confident then you might like to treat an example as a question, in which case cover it up and have a go yourself. Many of the examples given resemble assignment questions which will come your way, so follow them through diligently.

Question

Questions should not be avoided if you are determined to learn. Please do take the time to tackle each of the given questions, in the order in which they are presented. The order is important, as further knowledge and confidence is built upon previous knowledge and confidence. As an Online Learner it is important that the answers to questions are immediately available to you. Contact your Unit Tutor if you need help.

Challenge

You can really cement your new knowledge by undertaking the challenges. A challenge could be to download software and perform an exercise. An alternative challenge might involve a practical activity or other form of research.

Video

Videos on the web can be very useful supplements to your distance learning efforts. Wherever an online video(s) will help you then it will be hyperlinked at the appropriate point.

ELECTRICAL POWER

Polyphase Induction Motors

Essentials

The induction motor's presence is very much taken for granted. It drives such things as; electric pumps, industrial fans, compressors, conveyor belts, cranes and many other devices. Many of these devices are run at constant speed but, add some clever power electronics, and we have control of very large *variable* speed devices.

The torque (turning force, rotational strength) of an induction motor is produced by the interaction of alternating electromagnetic fields. The term 'induction' motor comes from the fact that the motor 'induces' its power from such electromagnetic fields. One major attraction of the induction motor is the fact that it does not need 'sliding' mechanical or electrical contacts, thus avoiding much of the maintenance that DC motors require.

The old saying is true: if it moves or gets hot, suspect it as the cause of the problem. Perhaps you have had, or still have, a PC/laptop with a hard drive (rotating disk containing masses of data, read by a mechanical arm)? Sometimes it can take such a computer to boot-up and stabilise maybe 10 minutes or more. A solid-state drive (SSD) on the other hand, can boot up in a few seconds. Why? – no moving parts, data is contained in silicon rather than a delicate high-speed moving disk. A chip lasts longer than a knee, a transistor last longer than a valve, a probe orbiting the earth will last longer than one orbiting the Sun, jackets last longer than socks, gums last longer than teeth, and, finally, women tend to last longer than men. Basically, friction causes wear, and so does heat. We want certain motors to be highly reliable, and hence reduce the amount of hot and moving parts within them.

An induction motor is supplied with AC current, and there can be multiple phases of AC, but usually just three. Due to the absence of many moving parts, the induction motor tends to be much cheaper and reliable than its DC counterpart.

Operation

So, how does an induction motor actually operate? Well, essentially, it needs a **rotating** magnetic field. Let's take a look at a typical induction motor in Figure 1. The rotor is always trying to keep up with the rotating magnetic field (generated by the stator) but is continuously dragged along behind it (a bit like a cyclist trying to gain an advantage by pedalling close behind a bus).

The stator is key, because it generates the 'flux' (the driving force, if you like). You know all about magnetic flux from your earlier studies on transformers. More recently perhaps, you have charged your phone wirelessly, taking advantage of such flux. Since things that rotate tend to be circular (the rotor), the stator surrounds this circular rotor, hence it provides a *radial* pattern of magnetic flux to it (a bit like viewing how your bike tyres see, and drive, the centre of the wheel, via the spokes). Of course, we have an air gap between

the stator and rotor (stator is stationary, rotor rotates). The stator's job is to produce electromagnetic fields, and because these fields are close to the circular rotor, we have interaction.

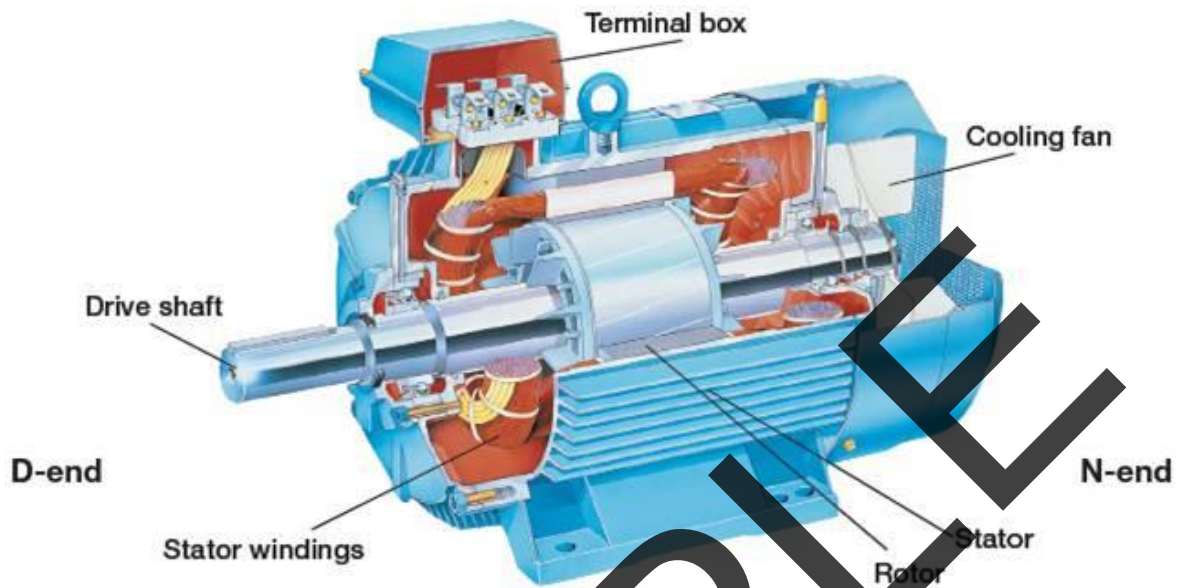

Figure 1: A typical induction motor

The interaction of electromagnetic fields with coils of wire is the primary thought we need to consider with induction motors. A good analogy is; you have your bike upside-down and are testing a wheel. You spin the wheel with your hand, and it rotates. However, the wheel will never spin faster than your hand moved. The speed of the wheel always lags behind the speed of your hand (friction prevents this). Another analogy; you know that if you put the accelerator pedal down by one inch in your sports car on a dry road it will go 100 mph, but you try it on a wet road one day, and it takes quite a bit longer to achieve that speed. In this scenario you are the stator and the movement of the car is the rotor (some slippage is involved).

The key to providing more torque, more power, is to provide more current to the stator coils, thus providing flux and power to the rotor windings, via the invisible magnetic fields. Remember, flux is the magic ingredient which provided invisible power from the stator to the rotor.

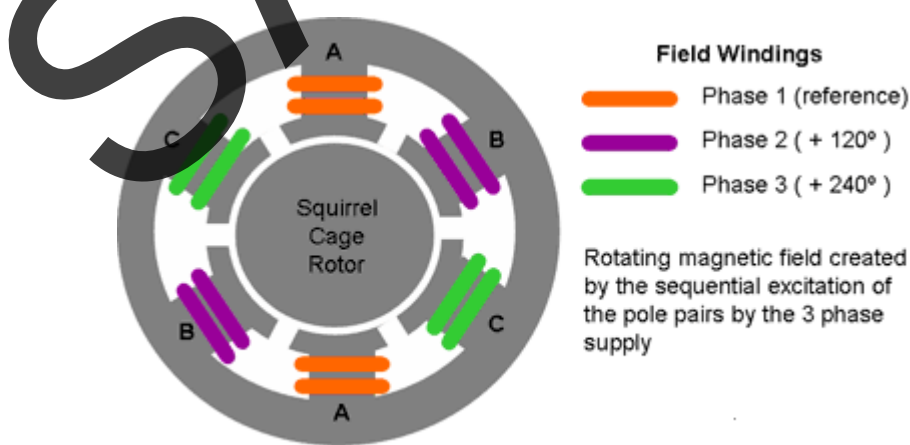

Figure 2: Stator windings and squirrel cage rotor

Vector Group

Both primary and secondary windings may be arranged in either a star (wye) or delta (mesh) configuration, as shown in figure 8.

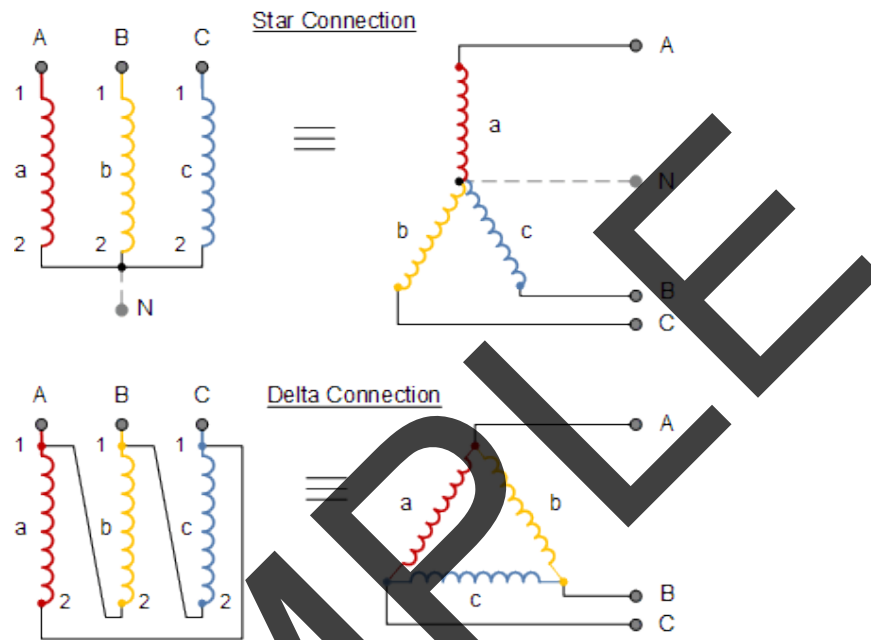

Figure 8: Transformer star and delta connections

The four main permutations of primary and secondary winding arrangements are shown in Figure 9.

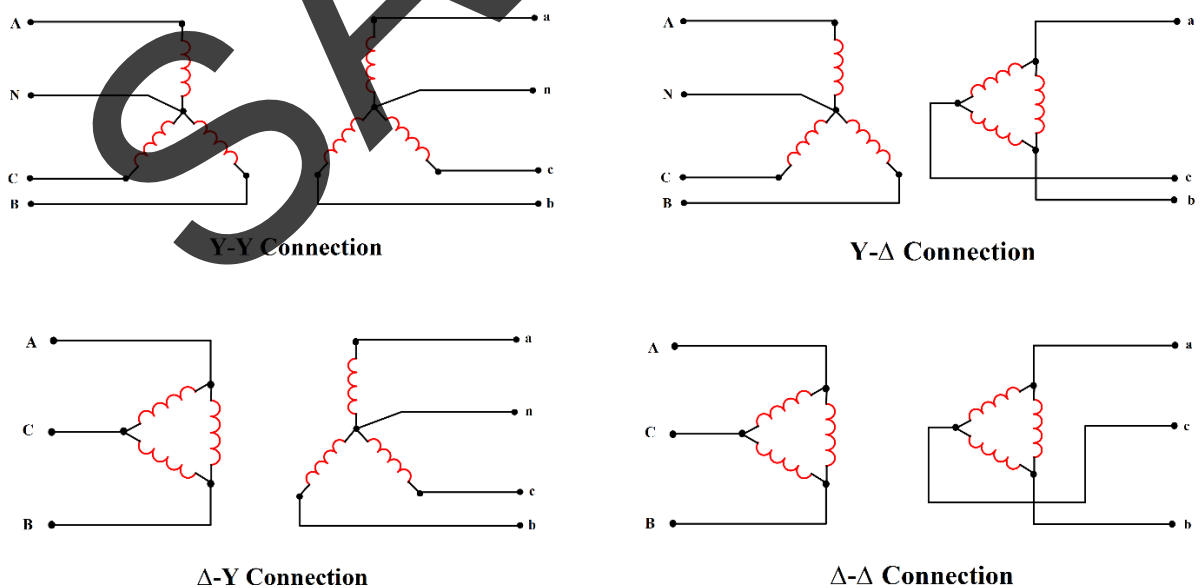

Figure 9: The four main primary-secondary arrangements

The vector group indicates how the transformer connections are arranged and is indicated by a code of two or three letters followed by a 'clock number' (see below). Vector groups are denoted as follows;

- **D or d**
 - Capital D for primary delta, lowercase d for secondary delta
- **Y or y**
 - Capital Y for primary wye (star), lowercase y for secondary wye
- **Z or z**
 - Zig-zag winding (also known as interconnected star)
- **III or iii**
 - Independent windings which need to be connected externally
- **N or n**
 - System neutral is connected to the high voltage side (N) or the low voltage side (n)

The vector group will always start with a capital letter.

Clock number

Using the high voltage winding as a reference, the low voltage winding may be in phase, lagging by 30 degrees, leading by 30 degrees or 180 degrees out of step. A clock analogy is commonly used to indicate the phase shift between primary and secondary, as per Figure 10.



Figure 10: Phase shift between primary and secondary represented by clock hour hand

Numbers are given to the phase shift, as follows;

- 0** No phase shift (same as 12 o'clock)
- 1** 30 degrees lag
- 6** 180 degrees shift (antiphase)
- 11** 30 degrees lead

Figure 11 shows a typical information plate on a large transformer. The relevant information, ringed in red for this particular example plate, indicates **Dyn11**, which translates as ...

- D** Primary configured as Delta (Mesh)
- Y** Secondary configured as Wye (Star)
- n** System neutral is connected to the low voltage side
- 11** Phase leads by 30 degrees

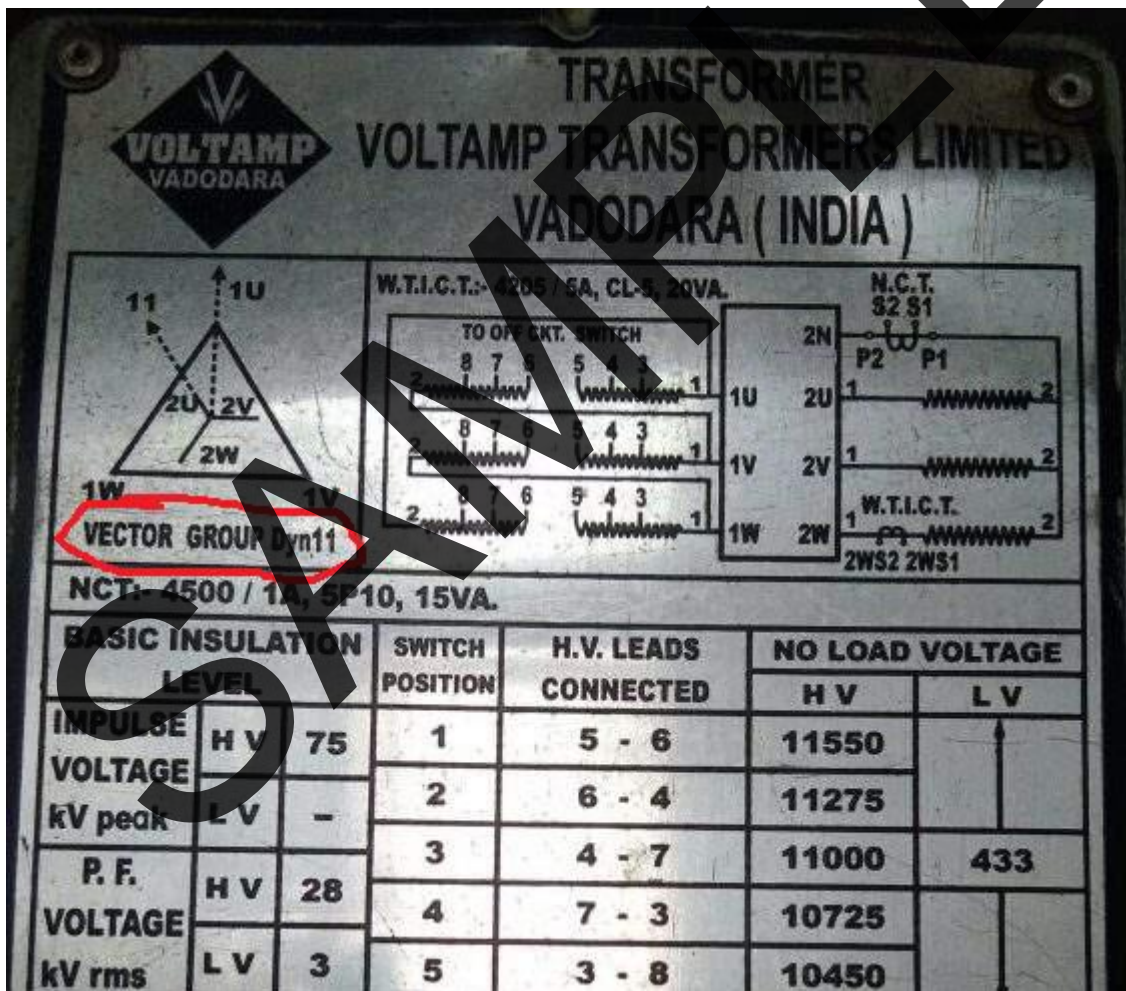

Figure 11: An example information plate on a three-phase transformer